



EasyGate

Swing & Sliding Speed Gates





The EasyGate speed gate range represents the latest innovation in entrance control systems, combining high security with user comfort. The combination of stainless steel together with glass, wood or other material (corian, black stainless steel or others) create an attractive aesthetic design. The powerful drive unit provides a large number of operating modes, good accessibility and a high level of personal safety.

A wide range of cabinet shapes, design and surface finishes, ensures that the turnstile will seamlessly fit into any interior decor.



SWING TECHNOLOGY

combines the slim design of the EasyGate cabinet with a high speed drive unit. Our designers focused on fitting swing speed gates to any location whilst keeping the ability to implement a wide range of optional accessories without limitation. Moreover our technology offers different Swing models for indoors, as well as outdoor installation with the additional option of altering the cabinet length and glass wing barrier height which provides the perfect solution for all projects.

SLIDING TECHNOLOGY

also known as speed gate technology has been developed by COMINFO to the highest design and security level. Sliding opening provides an intuitive and easy passage for the users. These speed gates are adaptable and a various accessories and terminals or readers are easily integrated. The large variety of shapes and materials used for each sliding speed gate makes this turnstile suitable for any interior.

C O N T E N T S

Swing Speed Gate Technology

- 4 EasyGate Superb
- 6 EasyGate Elite / EliteS
- 8 EasyGate LC
- 10 EasyGate IM
- 12 EasyGate SPT-G / R & SPTs-G / R
- 14 EasyGate SPD-G / R & SPDs-G / R
- 16 EasyGate SG / SR 1000

Sliding Speed Gate Technology

- 18 EasyGate LG
- 20 EasyGate LX / LH

Special Applications

- 22 EasyGate SPT Outdoor
- 24 EasyGate SPA
- 26 EasyGate SBG
- 28 e-Gate
- 30 EasyGate SPT-G Bike / SPT-R Bike
- 32 EasyGate SPT-G / SPT-R Bike Outdoor
- 34 Interlock gate

36 Specification Overview

40 Options & Accessories

42 Project Design

43 EasyGate Integration



EasyGate Superb

Type

Swing technology
1 wing / 2 wings
Square front

Safety & Security Detection

- 24 pairs of IR sensors
- Safety & Security levels
- Tailgating / Cross over detection

Dimensions

Cabinet height	990 mm	38.98"
Cabinet length	1 580 mm	55.12"
Cabinet width	99 mm	5.95"
Barrier height standard	990 mm	38.98"
Barrier height max.	1 800 mm	70.87"
Passage width standard ^[1]	650 mm	25.59"
Passage width max. ^[1]	1 100 mm	43.31"
	<i>for height of glass wing up to 1 400 mm</i>	
	max 920 mm	36.22"
	<i>for height of glass wing up to 1 800 mm</i>	

Special features*

Wide passage lane
Arc layout
Flag wing



EasyGate Superb / 990 mm

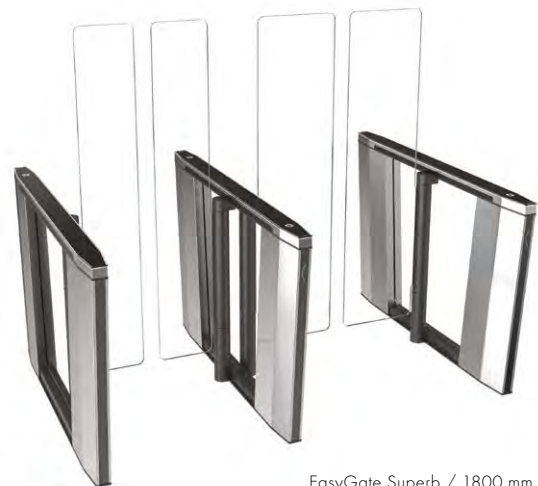

EasyGate Superb / 1800 mm



Materials and Colours

Frame	black RAL
Covers	brushed stainless steel
Top Lid	black glass
Barriers	tempered glass barrier panels (10 mm / 0.39")
Side infill panel	tempered glass panels (6 mm / 0.24")

Operating Environment

Indoor

Drive Mechanism

Fail-Safe
MCBF 5 000 000

Stand-by Power Consumption

22.6 W

Emergency Mode

Open automatically in the exit direction

Optional Accessories

- RFID reader bracket (flush mounted)
- Access Light / lane Light / Passage Light
- WAV player
- Pressure sensing top
- RF remote control
- EasyTouch / TouchPanel / T-MON SW
- SuperCap (emergency power back-up)
- Alternative surface finishes / Optional top Finishes
- Integration of LiftCall / Card collector / BarCode scanner
- Ramp LT

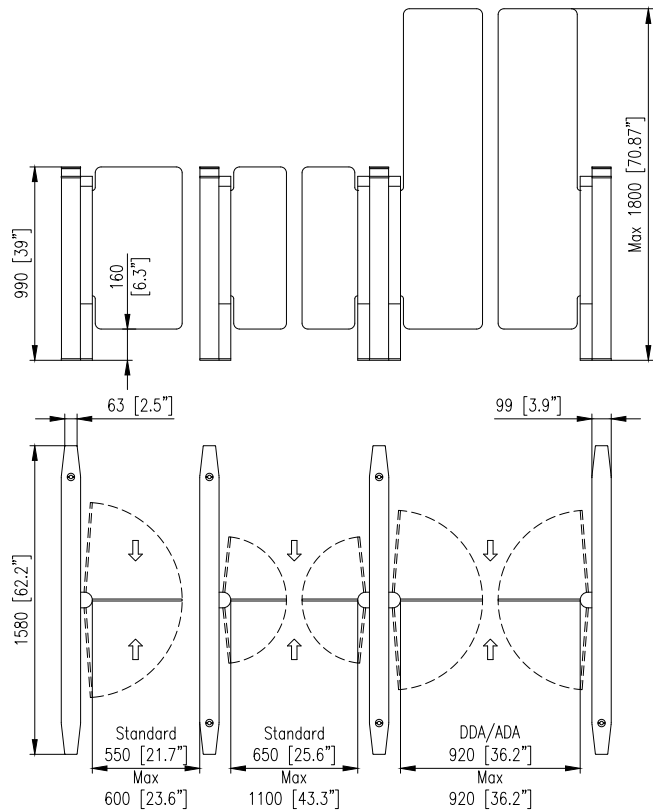



EasyGate Elite-G

EasyGate Elite-G / Elite-R

Type

Swing technology
 1 wing / 2 wings
 G model - round front
 R model - square front

Safety & Security Detection

- 18 pairs of IR sensors / 26 pairs of IR sensors*
- Safety & Security levels
- Tailgating / Cross over detection

Dimensions

Cabinet height	990 mm	38.98"
Cabinet length Elite	1 240 mm	48.80"
Cabinet width	132 mm	5.20"
Barrier height standard	990 mm	38.98"
Barrier height max.	1 800 mm	70.87"
Passage width standard ^[1]	650 mm	25.59"
Passage width max. ^[1]	1 100 mm	43.31"
	<i>for height of glass wing up to 1 400 mm</i>	
	max 920 mm	36.22"
	<i>for height of glass wing up to 1 800 mm</i>	

Special feature*

Wide passage lane
 Arc layout
 Flag wing



EasyGate Elite-G / 990 mm



EasyGate Elite-R / 1 800 mm

* Optional [1] For 2 wings type



EasyGate Elite-R

Materials and Colours

Frame	black RAL
Covers	black RAL
Top Lid	black glass
Barriers	tempered glass barrier panels (10 mm / 0.39")

Operating Environment

Indoor

Drive Mechanism

Fail-Safe
MCBF 5 000 000

Stand-by Power Consumption

22.6 W

Emergency Mode

Open automatically in the exit direction

Optional Accessories

- RFID reader bracket (flush mounted)
- Access Light / Edge Light / Lane Light / Wing Light
- WAV player
- Hinge capping
- Pressure sensing top
- RF remote control
- EasyTouch / TouchPanel / T-MON SW
- SuperCap (emergency power back-up)
- Alternative surface finishes / Optional top finishes
- Integration of LiftCall / Card collector / BarCode scanner
- Ramp LT

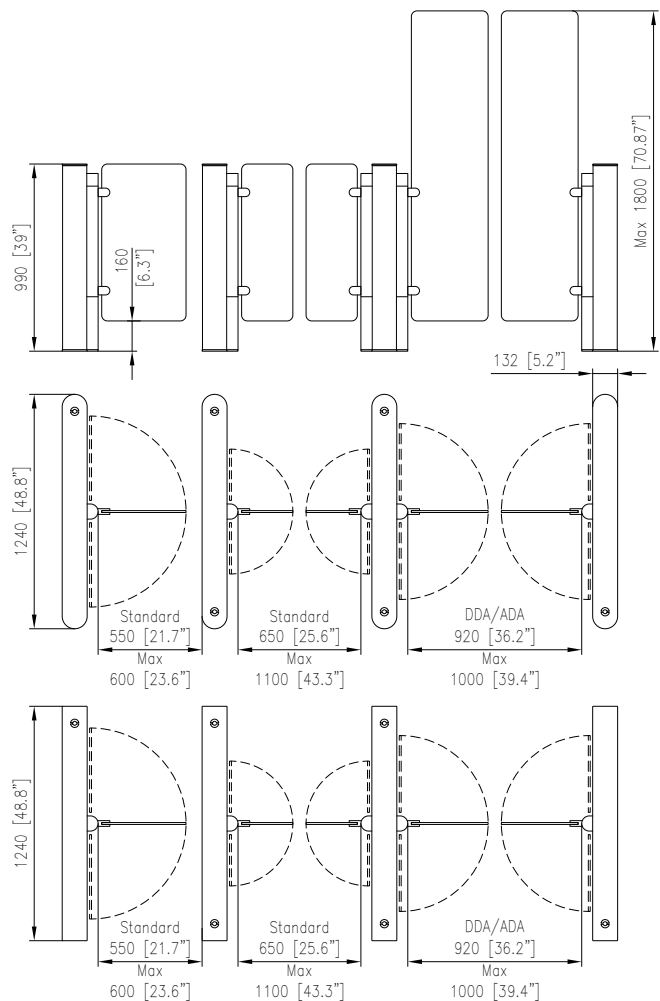



EasyGate LC

Type

Swing technology
1 wing / 2 wings
Square front

Safety & Security Detection

- 36 pairs of IR sensors
- Safety & Security levels
- Tailgating / Cross over detection

Dimensions

Cabinet height	990 mm	38.98"
Cabinet length	1 400 mm	55.12"
Cabinet width	150 mm	5.90"
Barrier height standard	990 mm	38.98"
Barrier height max.	1 800 mm	70.87"
Passage width standard ^[1]	650 mm	25.59"
Passage width max. ^[1]	1 100 mm	43.31"
	<i>for height of glass wing up to 1 400 mm</i>	
	max 920 mm	36.22"
	<i>for height of glass wing up to 1 800 mm</i>	

Special features*

Wide passage lane
Arc layout
Staggered / diagonal layout
Flag wing



EasyGate LC / 990 mm



EasyGate LC / 1 800 mm

* Optional [1] For 2 wings type



Materials and Colours

Covers	brushed stainless steel / black glass front and back
Top Lid	black glass
Barriers	tempered glass barrier panels (10 mm / 0.39")
Side infill panel	brushed stainless steel

Operating Environment

Indoor

Drive Mechanism

Fail-Safe
MCBF 5 000 000

Stand-by Power Consumption

22.6 W

Emergency Mode

Open automatically in the exit direction

Optional Accessories

- RFID reader bracket (flush mounted)
- Access Light / Lane Light / Wing Light
- Hinge capping
- WAV player
- Pressure sensing top
- RF remote control
- EasyTouch / TouchPanel / T-MON SW
- SuperCap (emergency power back-up)
- Alternative surface finishes / Optional top finishes
- Integration of LiftCall / Card collector / BarCode scanner
- Ramp LT

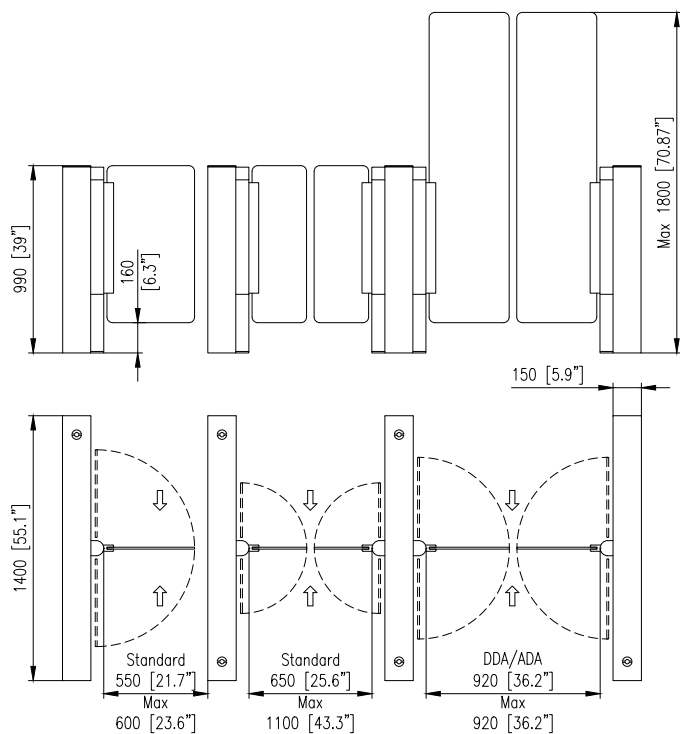



EasyGate IM

Type

Swing technology
1 wing / 2 wings
Square front

Safety & Security Detection

- 36 pairs of IR sensors
- Safety & Security levels
- Tailgating / Cross over detection

Dimensions

Cabinet height	995 mm	39.17"
Cabinet length	1 500 mm	59.10"
Cabinet width	210 mm	8.27"
Barrier height standard	995 mm	39.17"
Barrier height max.	1 800 mm	70.87"
Passage width standard ^[1]	650 mm	25.59"
Passage width max. ^[1]	1 050 mm	41.34"

Special features*

Heavy duty wing
Arc layout
Flag wing



EasyGate IM / 995 mm



EasyGate IM / 1 800 mm



Materials and Colours

Inner covers	brushed stainless steel
Cladding	corian
Barriers	tempered glass barrier panels (10 mm / 0.39")

Operating Environment

Indoor

Drive Mechanism

Magnetic Direct Drive motor with external tooth brake
MCBF 25 000 000

Stand-by Power Consumption

6.1 W

Emergency Mode

Open automatically in the exit direction
Pushthrough feature*

Optional Accessories

- RFID reader bracket (flush mounted)
- Access Light / Lane Light / Wing Light
- WAV player
- Hinge capping
- Pushthrough feature
- RF remote control
- EasyTouch / TouchPanel / T-MON SW
- SuperCap (emergency power back-up)
- Alternative surface finishes / Optional top finishes
- Integration of LiftCall / Card collector / BarCode scanner
- Ramp LT

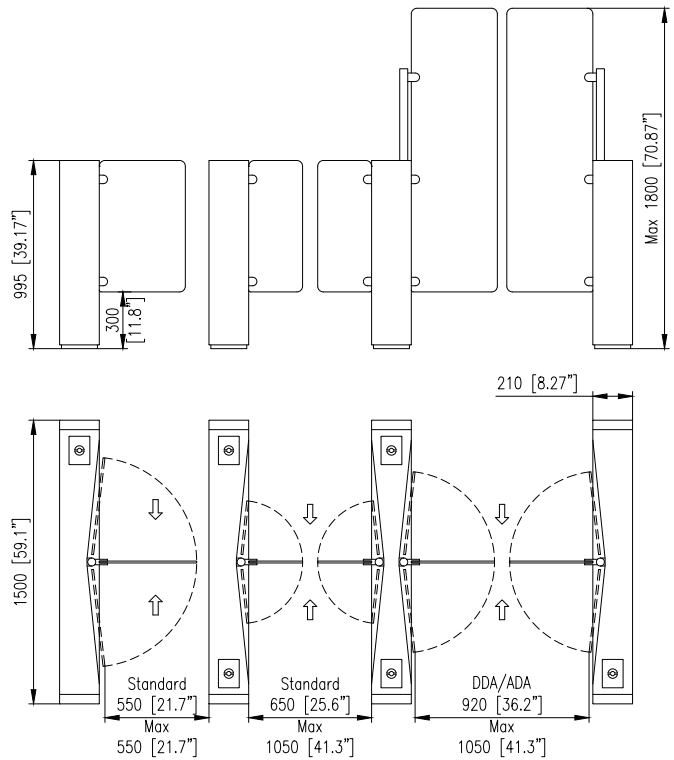



EasyGate SPT-R

EasyGate SPT-G / SPT-R & SPTs-G / SPTs-R

Type

Swing technology
 1 wing / 2 wings
 G model - round front
 R model - square front

Safety & Security Detection

- 36 pairs of IR sensors - SPT-G / SPT-R
- 24 pairs of IR sensors - SPTs-G / SPTs-R
- Safety & Security levels
- Tailgating / Cross over detection

Dimensions

Cabinet height	990 mm	38.39"
Cabinet length - SPT-G / SPT-R	1 500 mm	59.06"
Cabinet length - SPTs-G / SPTs-R	1 200 mm	47.24"
Barrier height standard	990 mm	38.98"
Barrier height max.	1 800 mm	70.87"
Passage width standard ^[1]	650 mm	25.59"
Passage width max. ^[1]	920 mm	36.22"

Special features*

Wide passage lane SPT ^[2]	921-1 200 mm	36.26"-47.24"
Wide passage lane SPTs ^[2]	921-1 050 mm	36.26"-41.34"
Extra wide passage lane ^[3]	1 201-1 400 mm	47.28"-55.12"
Heavy duty wing		
Arc layout		
Staggered / diagonal layout		
Flag wing		



EasyGate SPT-G / 990 mm



EasyGate SPTs-G / 990 mm



EasyGate SPT-R / 1 800 mm



EasyGate SPTs-R / 1 800 mm

* Optional [1] For 2 wings type [2] Dual opening mode
 [3] Cabinet length extended & Dual opening mode



EasyGate SPT-G

Materials and Colours

Covers	brushed stainless steel
Top Lid	black glass
Barriers	tempered glass barrier panels (10 mm / 0.39")
Side infill panel	tempered glass panels (6 mm / 0.24")

Operating Environment

Indoor

Drive Mechanism

Magnetic Direct Drive motor with external tooth brake
MCBF 25 000 000

Stand-by Power Consumption

6.1 W

Emergency Mode

Open automatically in the exit direction
Pushthrough feature*

Optional Accessories

- RFID reader bracket (flush mounted)
- Access Light/Lane Light/Edge Light/Wing Light/Passage Light
- WAV player
- Hinge capping
- Pushthrough feature / Pressure sensing top
- RF remote control
- EasyTouch / TouchPanel / T-MON SW / RF remote control
- SuperCap (emergency power back-up)
- Alternative surface finishes / Optional top finishes
- Integration of LiftCall / Card collector / BarCode scanner
- Ramp LT

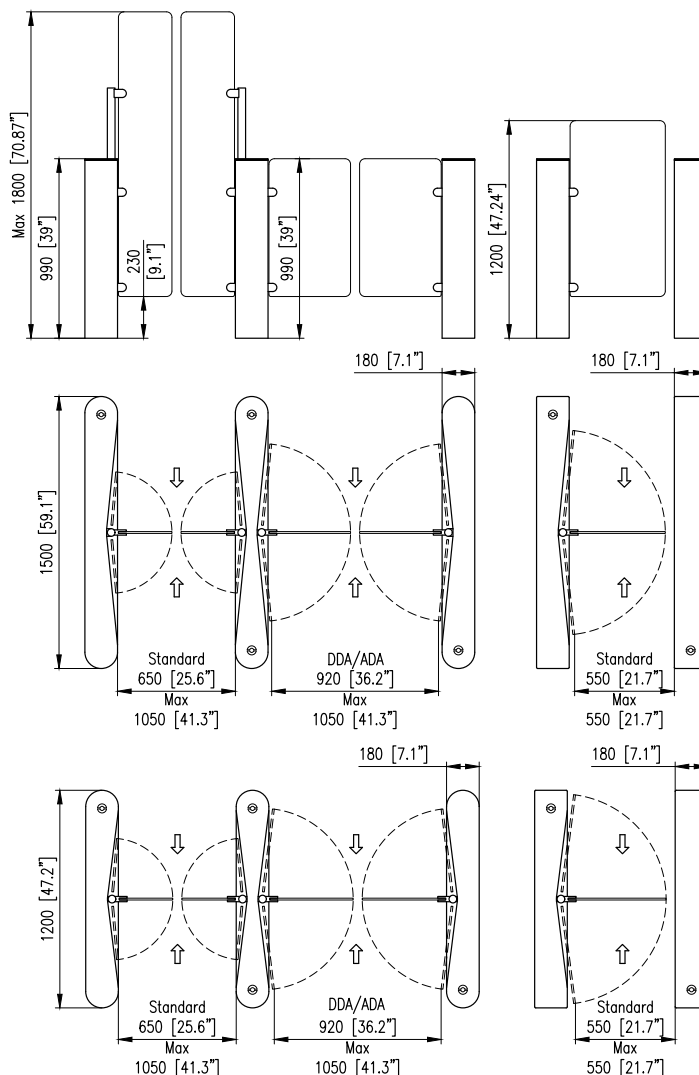



EasyGate SPD-R

EasyGate SPD-G / SPD-R & SPDs-G / SPDs-R

Type

Swing technology
 1 wing / 2 wings
 G model - round front
 R model - square front

Safety & Security Detection

- 36 pairs of IR sensors - SPD-G / SPD-R
- 24 pairs of IR sensors - SPDs-G / SPDs-R
- Safety & Security levels
- Tailgating / Cross over detection

Dimensions

Cabinet height	990 mm	38.39"
Cabinet length - SPD-G / SPD-R	1 500 mm	59.06"
Cabinet length - SPDs-G / SPDs-R	1 200 mm	47.24"
Cabinet width	180 mm	7.09"
Barrier height	855 mm	33.66"
Passage width standard ^[1]	650 mm	25.59"
Passage width max. ^[1]	920 mm	36.22"

Special features*

Wide passage lane SPD ^[2] 921-1 200 mm 36.26"-47.24"
 Wide passage lane SPDs ^[2] 921-1 050 mm 36.26"-41.34"
 Extra wide passage lane ^[3] 1 201-1 400 mm 47.28"-55.12"
 Heavy duty wing
 Arc layout
 Staggered / diagonal layout



EasyGate SPD-G / 855 mm



EasyGate SPDs-G / 855 mm



EasyGate SPD-R / 855 mm



EasyGate SPDs-R / 855 mm

* Optional [1] For 2 wings type [2] Dual opening mode
 [3] Cabinet length extended & Dual opening mode



EasyGate SPD-G

Materials and Colours

Covers	brushed stainless steel
Top Lid	black glass
Barriers	tempered glass barrier panels (10 mm / 0.39")
Side infill panel	tempered glass panels (6 mm / 0.24")

Operating Environment

Indoor

Drive Mechanism

Magnetic Direct Drive motor with external tooth brake
MCBF 25 000 000

Stand-by Power Consumption

6.1 W

Emergency Mode

Open automatically in the exit direction
Pushthrough feature*

Optional Accessories

- RFID reader bracket (flush mounted)
- Access Light / Lane Light / Edge Light / Wing light / Passage Light
- WAV player
- Hinge capping
- Pushthrough feature / Pressure sensing top
- EasyTouch / TouchPanel / T-MON SW / RF remote control
- SuperCap (emergency power back-up)
- Alternative surface finishes / Optional top finishes
- Integration of LiftCall / Card collector / BarCode scanner
- Ramp LT

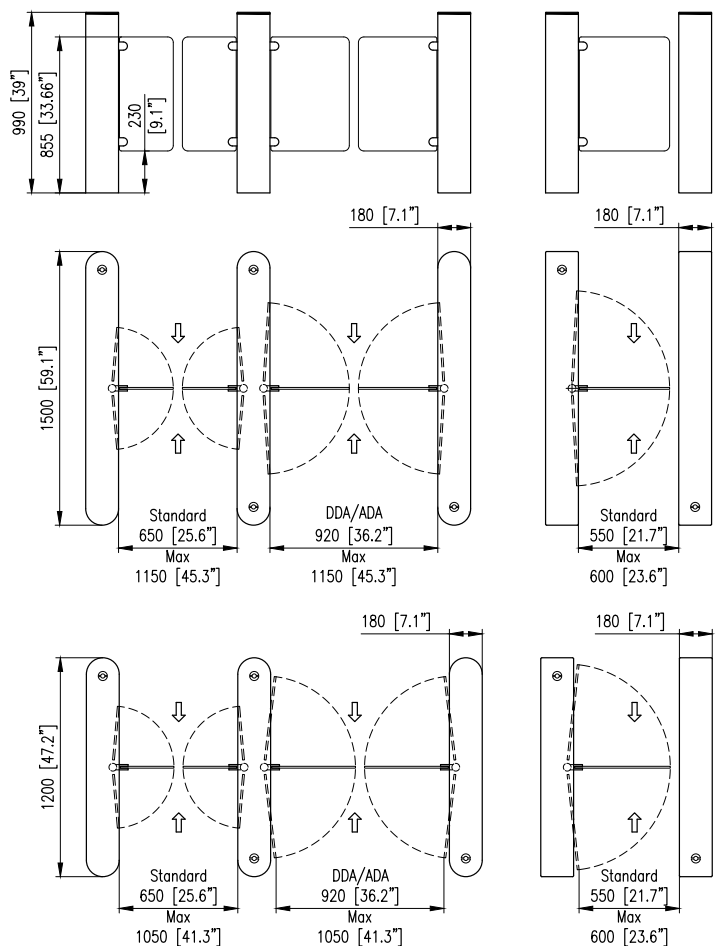



EasyGate SG

EasyGate SG / SR 1000

Type

Swing technology
 1 000 (length of cabinet in mm)
 1 wing / 2 wings
 SG model - round front
 SR model - square front

Safety & Security Detection

- 24 pairs of IR sensors
- Safety & Security levels
- Tailgating / Cross over detection

Dimensions

Cabinet height	990 mm	38.98"
Cabinet length	1 000 mm	39.37"
Cabinet width	120 mm	4.72"
Barrier height	835 mm	32.87"
Passage width standard ^[1]	650 mm	25.59"
Passage width max. ^[1]	920 mm	36.22"

Special features*

Wide passage lane
 Arc layout
 Staggered / diagonal layout



EasyGate SG 1000 / 835 mm



EasyGate SR 1000 / 835 mm

* Optional [1] For 2 wings type



EasyGate SR

Materials and Colours

Covers	brushed stainless steel
Top Lid	black glass
Barriers	tempered glass barrier panels (10 mm / 0.39")

Operating Environment

Indoor

Drive Mechanism

Fail-Safe
MCBF 5 000 000

Stand-by Power Consumption

22.6 W

Emergency Mode

Open automatically in the exit direction

Optional Accessories

- RFID reader bracket (flush mounted)
- Access Light / Lane Light / Wing Light
- WAV player
- Hinge capping
- RF remote control
- EasyTouch / TouchPanel / T-MON SW
- SuperCap (emergency power back-up)
- Alternative surface finishes / Optional top finishes
- Integration of BarCode scanner
- Ramp LT

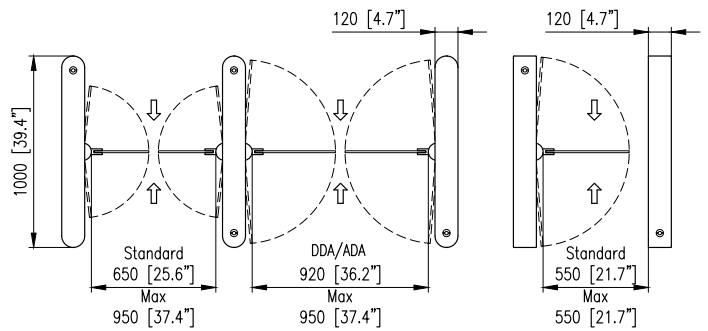
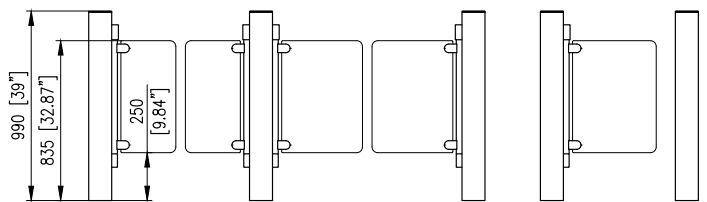



EasyGate LG

Type

Sliding technology
 940 / 1 200-1 800 (height of glass barrier in mm)
 2 wings
 Round front

Safety & Security Detection

- 42 pairs of IR sensors
- Safety & Security levels
- Tailgating / Cross over detection

Dimensions

Cabinet height	990 mm	38.98"
Cabinet length	1 550 mm	61.02"
Cabinet width	330 mm	12.99"
DDA cabinet width	510 mm	20.08"
Barrier height	940 mm	37.01"
	1 200-1 800 mm	47.24"-70.87"
Passage width standard	570 mm	22.44"
Passage width max.	920 mm	36.22"



EasyGate LG / 1200 mm



EasyGate LG / 940 mm



Materials and Colours

Covers	brushed stainless steel
Top Lid	brushed stainless steel
Barriers	tempered glass barrier panels (8 mm / 0.31")

Operating Environment

Indoor

Drive Mechanism

Magnetic Direct Drive motor
MCBF 25 000 000

Stand-by Power Consumption

83.4 W

Emergency Mode

Open automatically

Optional Accessories

- RFID reader bracket (flush mounted)
- Access Light / Lane Light / Wing Light (only for 940 model)
- WAV player
- Pressure sensing top
- USB convertor / Ethernet convertor
- RF remote control
- EasyTouch / TouchPanel / T-MON SW
- SuperCap (emergency power back-up)
- Alternative surface finishes / Optional top finishes
- Integration of LiftCall / Card collector / BarCode scanner
- Ramp LT

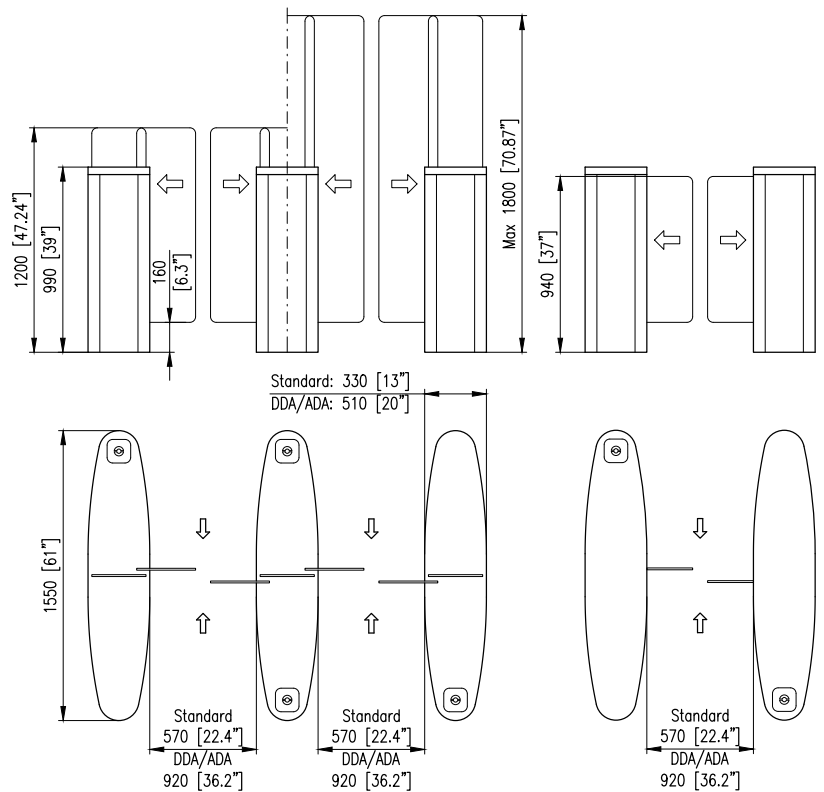



EasyGate LX / 1200

EasyGate LX / LH

Type

Sliding technology
 940 / 1 200-1 800 (height of glass barrier in mm)
 Rectangular wings - standard
 V-shaped wings - optional
 2 wings
 LX model - round front
 LH model - square front

Safety & Security Detection

- 40 pairs of IR sensors
- Safety & Security levels
- Tailgating / Cross over detection

Dimensions

Cabinet height	990 mm	38.98"
Cabinet length	1 700 mm	66.93"
Cabinet width	320 mm	12.60"
DDA cabinet width	500 mm	19.68"
Barrier height	940 mm	37.01"
	1 200-1 800 mm	47.24"-70.87"
Passage width standard	570 mm	22.44"
Passage width max.	920 mm	36.22"



EasyGate LX / 940 mm
V-shaped wings



EasyGate LX / 1 200 mm
Rectangular wings



EasyGate LH / 940 mm
V-shaped wings



EasyGate LH / 940 mm
Rectangular wings



EasyGate LH / 940

Materials and Colours

Covers	brushed stainless steel
Top Lid	brushed stainless steel with black top ends
Barriers	tempered glass barrier panels (8 mm / 0.31")

Operating Environment

Indoor

Drive Mechanism

Fail-Safe

Emergency Mode

Open automatically

Optional Accessories

- RFID reader bracket (flush mounted)
- Access Light / Lane Light / Wing Light (only for 940 model)
- WAV player
- Outdoor package
- USB convertor / Ethernet convertor
- RF remote control
- EasyTouch / TouchPanel / T-MON SW
- SuperCap (emergency power back-up)
- Alternative surface finishes / Optional top finishes
- Integration of LiftCall / Card collector / BarCode scanner
- Ramp LT

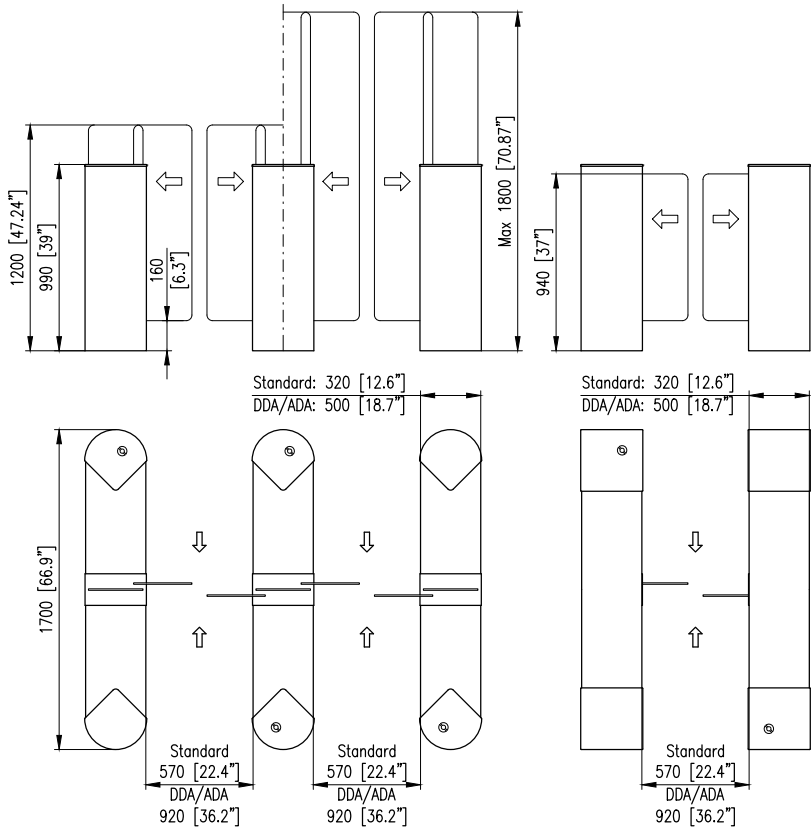



EasyGate SPT-G Outdoor / SPT-R Outdoor

Type

Swing technology developed to withstand harsh outdoor conditions - IP 53

1 wing / 2 wings

G model - round front

R model - square front

Safety & Security Detection

- 36 pairs of IR sensors
- Safety & Security levels
- Tailgating / Cross over detection

Dimensions

Cabinet height	990 mm	39"
Cabinet length	1 500 mm	59.06"
Cabinet width	210 mm	8.30"
Barrier height standard	1 400 mm	55.12"
Barrier height max.	1 800 mm	70.87"
Passage width standard ^[1]	650 mm	25.59"
Passage width max. ^[1]	1 050 mm	41.34"

Special features*

Heavy duty wing

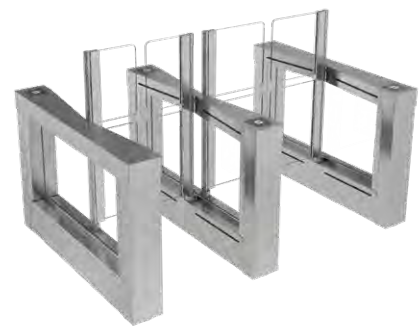

EasyGate SPT-R Outdoor / 1 400 mm



EasyGate SPT-G Outdoor / 1 800 mm



Materials and Colours

Covers	brushed stainless steel
Top Lid	stainless steel
Barriers	tempered glass barrier panels (10 mm / 0.39")
Side infill panel	tempered glass panels (6 mm / 0.24")

Operating Environment

Outdoor - IP 53

Drive Mechanism

Magnetic Direct Drive motor with external tooth brake
MCBF 25 000 000

Stand-by Power Consumption

6.1 W

Emergency Mode

Open automatically in the exit direction
Pushthrough feature*

Optional Accessories

- RFID reader bracket (flush mounted)
- Access Light / Lane Light / Wing Light
- WAV player
- Hinge capping
- Pushthrough feature / Pressure sensing top
- RF remote control
- EasyTouch / TouchPanel / T-MON SW
- SuperCap (emergency power back-up)
- Alternative surface finishes
- Integration of Barcode and QR code scanner
- Ramp LT

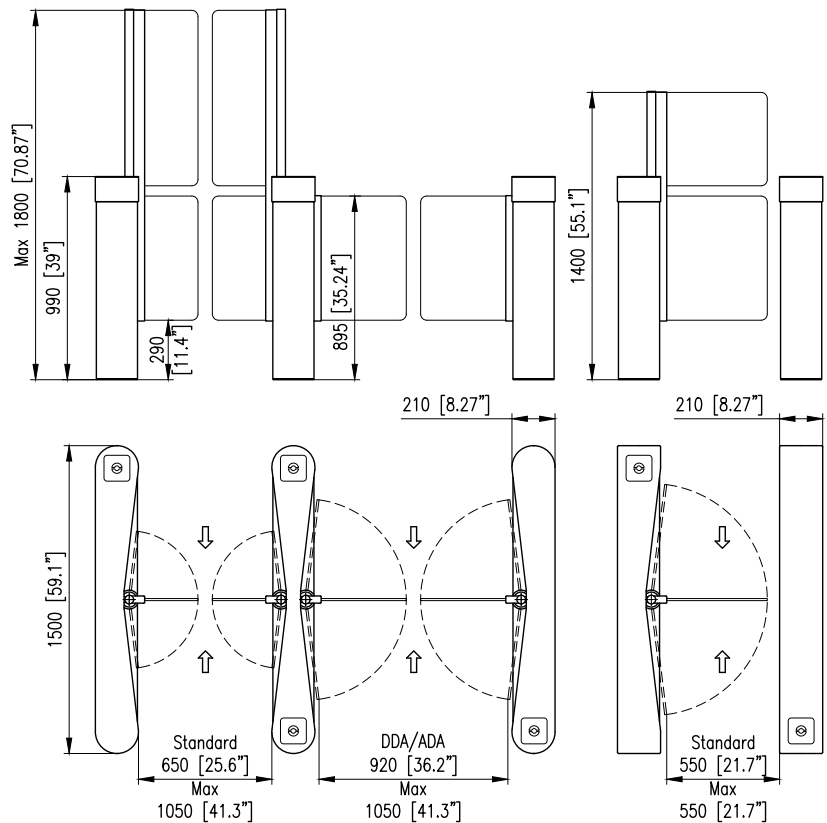



EasyGate SPA (Speed Gate for Paid Access)

Type

Swing technology
1 wing / 2 wings*
Square front

Safety & Security Detection

- 27 pairs of IR sensors
- Safety & Security levels
- Tailgating / Cross over detection

Dimensions

Cabinet height	1 400 mm	55.12"
Cabinet length	1 200 mm	47.24"
Cabinet width	180 mm	7.09"
Barrier height	1 400 mm	55.12"
Passage width standard	550 mm	21.65"
Passage width max.	920 mm	36.22"



EasyGate SPA ECO / 1 400 mm



EasyGate SPA Premium / 1 400 mm

* EasyGate SPA ECO / ECO+ feature master cabinet and sensor wall, respectively railings with sensors. EasyGate SPA Premium features master cabinet and side cabinet.



Materials and Colours

Frame	brushed stainless steel
Barriers	tempered glass barrier panels (10 mm / 0.39")
Side infill panel	tempered glass panels (8 mm / 0.31")

Operating Environment

Indoor

Drive Mechanism

Magnetic Direct Drive motor with external tooth brake
MCBF 25 000 000

Stand-by Power Consumption

29.3 W

Emergency Mode

Open automatically in the exit direction
Pushthrough feature*

Optional Accessories

- RFID reader bracket (flush mounted)
- Lane Light / Wing light/ Coin input Light
- WAV player
- Hinge capping
- Pushthrough
- EasyTouch / TouchPanel / T-MON SW / RF remote control
- SuperCap (emergency power back-up)
- Emergency push button
- Alternative surface finishes
- Integration of Cashless payment system (Receipt & coupon thermal printer)
- Ramp LT

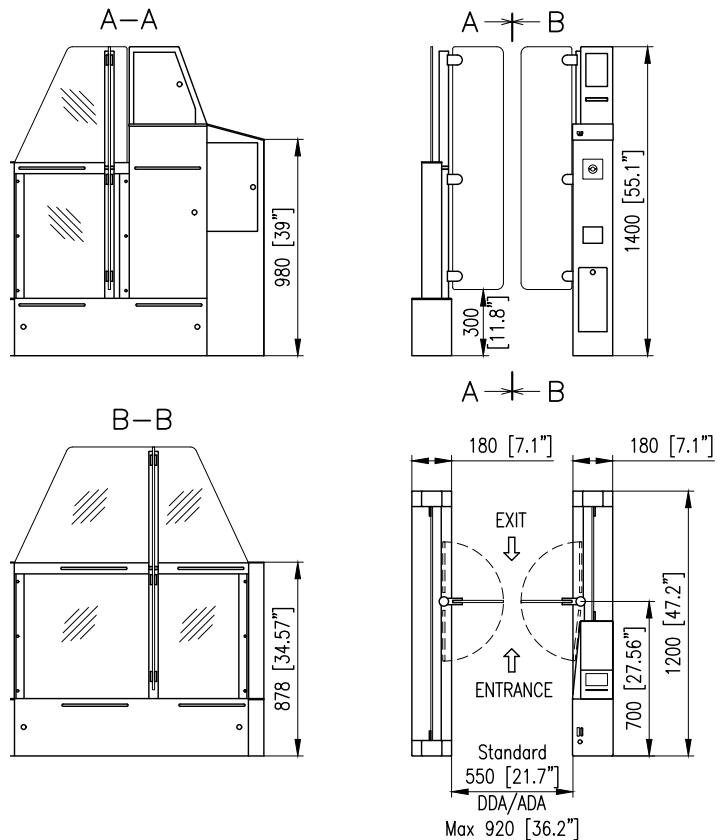



EasyGate SBG (Self Boarding Gate for Airports)

Type

Swing technology
2 wings
Square front

Safety & Security Detection

- SITA Protocol Certified
- Boarding pass scanner
- 36 pairs of IR sensors
- Safety & Security levels
- Tailgating / Cross over detection

Dimensions

Cabinet height	990 mm	39"
Cabinet length	1 500 mm	59.06"
Cabinet width	210 mm	8.3"
Barrier height	990 mm	39"
Passage width standard ^[1]	650 mm	25.6"
Passage width max. ^[1]	1 050 mm	41.3"

Special features*

Wide passage lane ^[1] 921-1 200 mm 36.26"-47.24"
 Extra wide passage lane ^[2] 1 201-1 400 mm 47.28"-55.12"
 Heavy duty wing
 Arc layout
 Staggered / diagonal layout

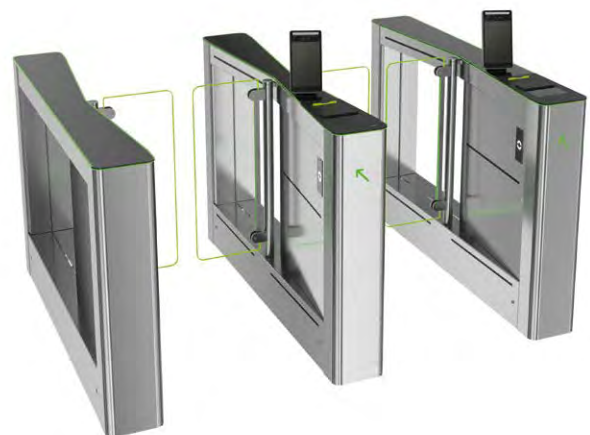

EasyGate SBG / 990 mm

* Optional [1] Dual opening mode
 [2] Cabinet length extended & Dual opening mode



Materials and Colours

Covers	brushed stainless steel
Top Lid	black glass
Barriers	tempered glass barrier panels (10 mm / 0.39")
Side infill panel	tempered laminated glass panels (10 mm / 0.39")

Operating Environment

Indoor

Drive Mechanism

Magnetic Direct Drive motor with external tooth brake
MCBF 25 000 000

Stand-by Power Consumption

30.9 W

Emergency Mode

Open automatically in the exit direction

Optional Accessories

- Boarding pass reader, Passport reader
- Thermal printer
- Biometric device, Thermal infrared camera
- RFID reader
- Lane Light / Wing Light / Passage Light
- WAV player
- EasyTouch / TouchPanel / T-MON SW
- SuperCap (emergency power back-up)
- Emergency push button
- Alternative surface finishes
- Ramp LT

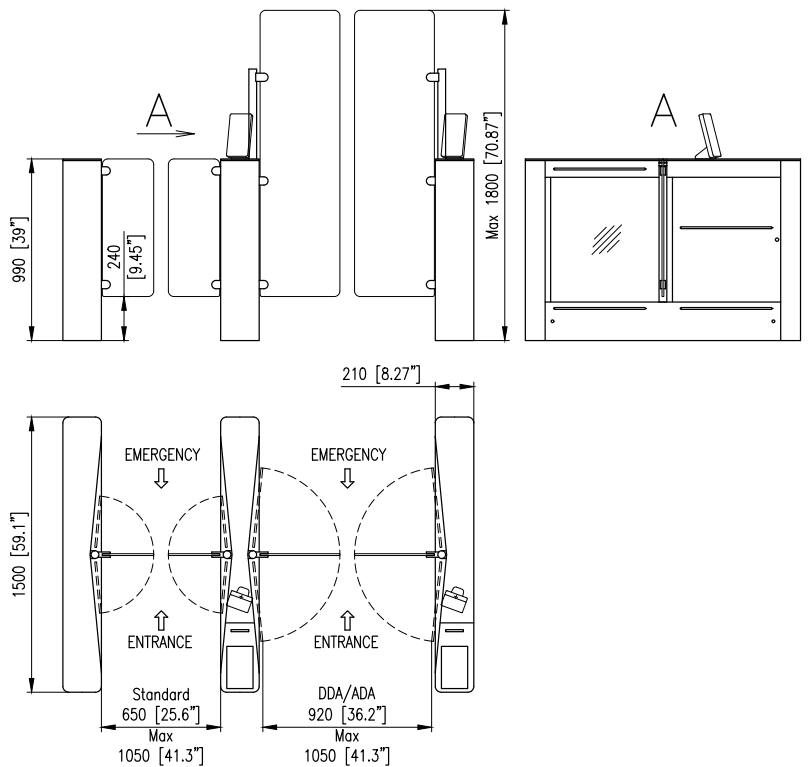



e-Gate (Automated Border Control)

Type

Automated Border Control
 Interlock technology (4 wings glass barriers)
 Swing opening of glass barriers
 Custom integration of any 3rd party equipment

Safety & Security Detection

- 78 pairs of IR sensors per passage lane
- Safety & Security levels
- Tailgating / Crossover detection
- Leftover luggage detection
- 7" LCD Screen

Dimensions

Cabinet height	990 mm	38.98"
Cabinet length	2 870 mm	112.99"
Cabinet width	240 mm	9.45"
Barrier height	1 200-1 800 mm	47.27"-70.87"
Passage width standard	650 mm	25.6"
Passage width max.	1 050 mm	41.3"
Facial recognition totem height	1 950 mm	76.77"



E-gate / 1 600 mm



Materials and Colours

Covers	brushed stainless steel
Cabinet base	stainless steel black RAL
Barriers	tempered glass barrier panels (10 mm / 0.39")
Side infill panel	tempered laminated glass panels (10 mm / 0.39")

Operating Environment

Indoor

Drive Mechanism

Magnetic Direct Drive motor with external tooth brake
MCBF 25 000 000

Emergency Mode

Dedicated emergency (Fire alarm) input for automatic opening of wing barrier when Emergency signal is activated

Optional Accessories

- Smart card reader for ID card, Passport reader
- Biometric device, Thermal infrared camera
- RFID reader
- BarCode scanner
- Pole for CCTV camera
- Lane light
- WAV player
- Wing light / Hinge capping
- Pushthrough feature
- EasyTouch / TouchPanel / T-MON SW
- SuperCap (emergency power back-up)
- Integration for industrial PC with brackets
- Ramp LT

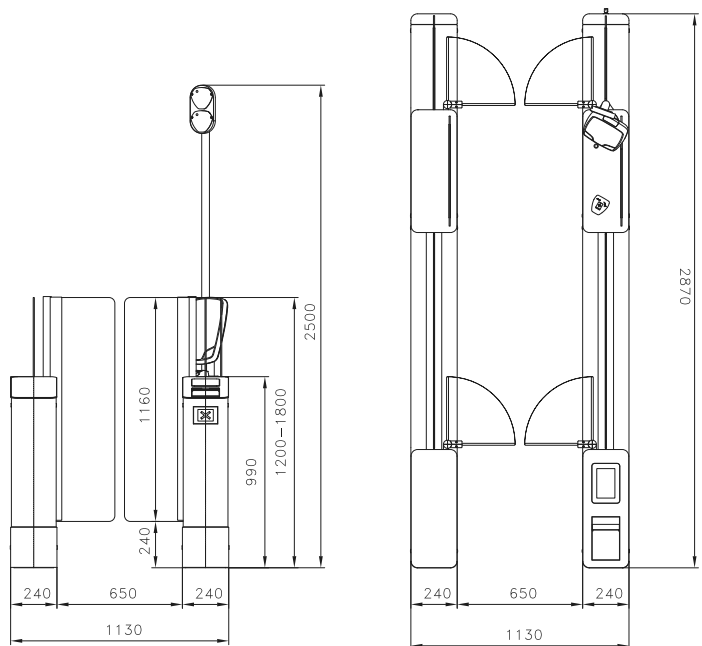



EasyGate SPT-G Bike

EasyGate SPT-G Bike / SPT-R Bike

Type

Swing technology
 2 wings
 G model - round front
 R model - square front

Safety & Security Detection

- 36 pairs of IR sensors
- Induction loop
- Safety & Security levels
- Tailgating / Cross over detection

Dimensions

Cabinet height	975 mm	38.39"
Cabinet length	2000 mm	78.74"
Cabinet width	180 mm	7.09"
Barrier height standard	1 200 mm	47.24"
Barrier height max.	1 800 mm	70.87"
Passage width standard	920 mm	36.20"
Passage width max.	990 mm	38.97"

Special features

Z-Shape tempered glass barrier panels
 Heavy duty wings*
 Cabinet extension for mass transit terminals*



EasyGate SPT-G Bike / 1 800 mm



EasyGate SPT-R Bike / 1 800 mm

* Optional



EasyGate SPT-G Bike

Materials and Colours

Covers	brushed stainless steel
Top Lid	black glass
Barriers	Z-Shape tempered glass barrier panels (10 mm / 0.39")
Side infill panel	tempered glass panels (6 mm / 0.24")

Operating Environment

Indoor

Drive Mechanism

Magnetic Direct Drive motor with external tooth brake
MCBF 25 000 000

Emergency Mode

Open automatically in the exit direction
Pushthrough feature*

Optional Accessories

- RFID reader bracket (flush mounted)
- Access Light / Lane Light / Wing Light
- WAV player
- Hinge capping
- Pushthrough feature / Pressure sensing top
- EasyTouch/TouchPanel/T-MON SW/RF remote control
- SuperCap (emergency power back-up)
- Alternative surface finishes / Optional top finishes
- Integration of LiftCall / Card collector / BarCode scanner
- Ramp LT / Bike
- Loop-to-concrete package

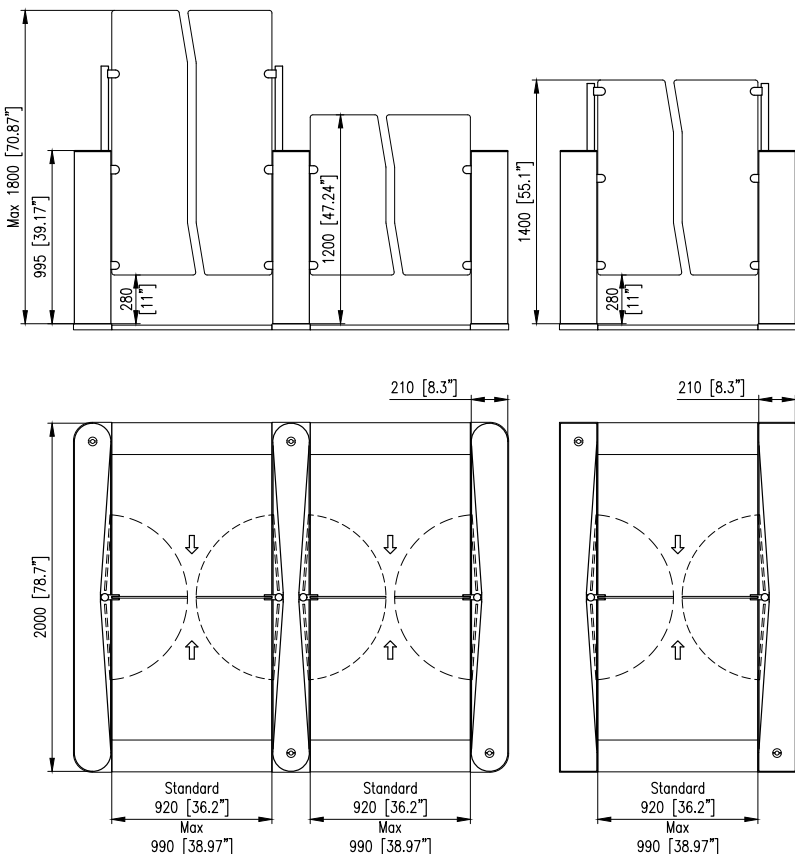



EasyGate SPT-G / SPT-R Bike Outdoor

Type

Swing technology
 2 wings
 G model - round front
 R model - square front

Safety & Security Detection

- 36 pairs of IR sensors
- Induction loop
- Safety & Security levels
- Tailgating / Cross over detection

Dimensions

Cabinet height	975 mm	38.38"
Cabinet length	2000 mm	78.74"
Cabinet width	210 mm	8.30"
Barrier height standard	1200 mm	47.24"
Barrier height max.	1800 mm	70.87"
Passage width standard	920 mm	36.20"
Passage width max.	990 mm	38.97"

Special features

Z-Shape tempered glass barrier panels
 Heavy duty wings*
 Cabinet extension for mass transit terminals*



EasyGate SPT-R Bike Outdoor / 1800 mm



EasyGate SPT-G Bike Outdoor / 1800 mm

* Optional



Materials and Colours

Covers	brushed stainless steel
Top Lid	stainless steel
Barriers	Z-Shape tempered glass barrier panels (10 mm / 0.39")
Side infill panel	tempered glass panels (6 mm / 0.24")

Operating Environment

Outdoor - IP 53

Drive Mechanism

Magnetic Direct Drive motor with external tooth brake
MCBF 25 000 000

Emergency Mode

Open automatically in the exit direction
Pushthrough feature*

Optional Accessories

- RFID reader bracket (flush mounted)
- Access Light / Lane Light / Wing Light
- WAV player
- Hinge capping
- Pushthrough feature / Pressure sensing top
- RF remote control
- EasyTouch / TouchPanel / T-MON SW
- SuperCap (emergency power back-up)
- Alternative surface finishes / Optional top finishes
- Ramp LT / Bike
- Loop-to-concrete package

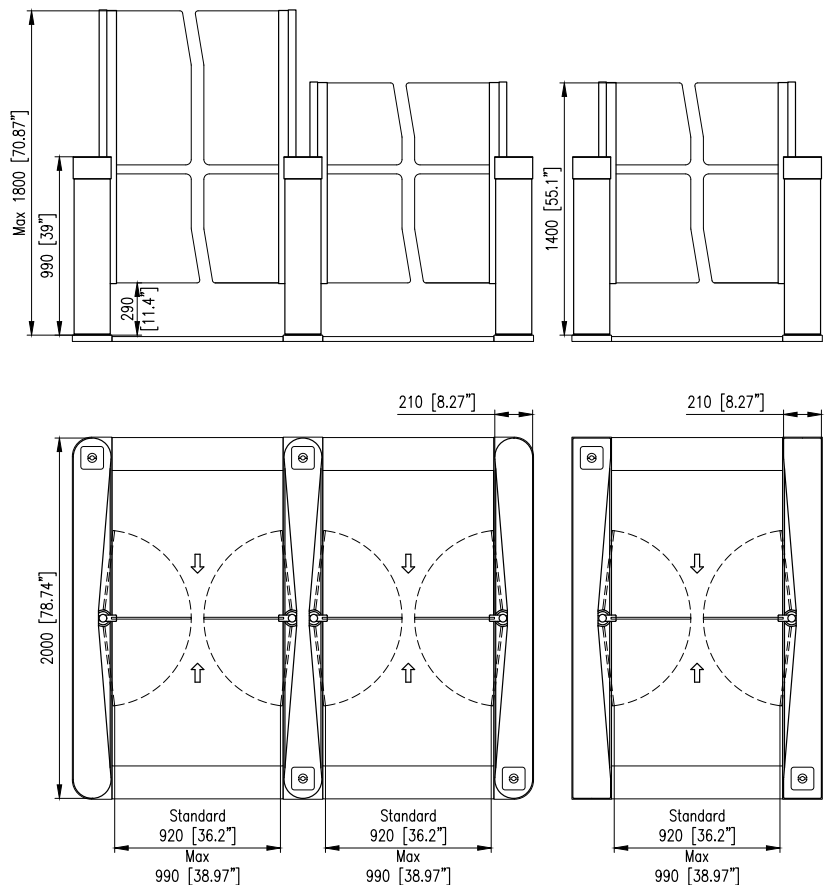



Interlock Gate (High Security Double Speed Gate)

Type

Swing technology
 4 wings
 G model - round front
 R model - square front

Safety & Security Detection

- 75 pairs of IR sensors
- Safety & Security levels
- Tailgating / Cross over detection

Dimensions

Cabinet height	975 mm	38.39"
Cabinet length	2 900 mm	114.77"
Cabinet width	180 mm	7.09"
Barrier height standard	1 200 mm	47.24"
Barrier height max.	1 800 mm	70.87"
Passage width standard ^[1]	650 mm	25.59"
Passage width max. ^[1]	920 mm	36.22"

Special features*

Wide passage lane ^[2] 921-1 200 mm 36.26"-47.24"
 Extra wide passage lane ^[3] 1 201-1 400 mm 47.28"-55.12"
 Heavy duty wing
 Flag wing



Interlock gate / 1800 mm



Materials and Colours

Covers	brushed stainless steel
Top Lid	black glass
Barriers	tempered glass barrier panels (10 mm / 0.39")
Side infill panel	tempered glass panels (6 mm / 0.24")

Operating Environment

Indoor

Drive Mechanism

Magnetic Direct Drive motor with external tooth brake
MCBF 25 000 000

Emergency Mode

Open automatically in the exit direction
Pushthrough feature*

Optional Accessories

- RFID reader bracket (flush mounted)
- Access Light / Lane Light / Edge Light / Wing light
- WAV player
- Hinge capping
- Pushthrough feature / Pressure sensing top
- EasyTouch / TouchPanel / T-MON SW
- SuperCap (emergency power back-up)
- Alternative surface finishes / Optional top finishes
- Integration of LiftCall / Card collector / BarCode scanner
- Ramp LT

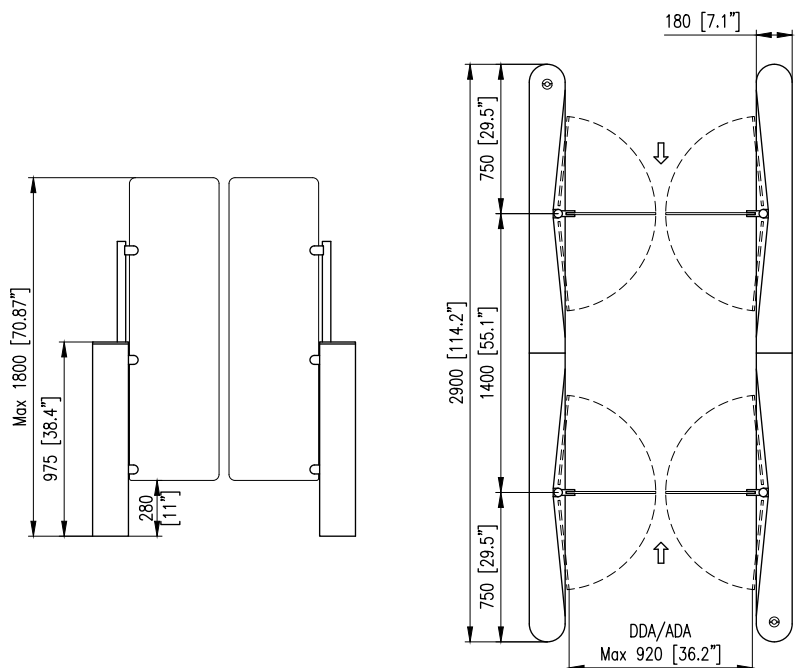

EasyGate – Swing Technology Overview



Type	Superb	Elite-G / Elite-R
Shape of cabinet - rounded / square	- / •	• / •
Available models - 1 wing / 2 wings	• / •	• / •
Dimensions		
Cabinet Height in mm (inches)	990 / 38.98"	990 / 38.98"
Cabinet Length in mm (inches)	1 580 / 62.20"	1 240 / 48.80"
Cabinet Width in mm (inches)	99 / 3.90"	132 / 5.20"
Glass wing barrier height in mm (inches)	up to 1 800 / 70.87"	up to 1 800 / 70.87"
Glass wing barrier thickness in mm (inches)	10 / 0.39"	10 / 0.39"
DDA (ADA) Compliant	•	•
Standard Material		
Stainless steel cabinet (AISI 304) / Special material	• / -	- / •
Stainless steel top lid (AISI 304) / Glass top Lid / Corian	- / • / -	- / • / -
Safety Features		
Emergency (Fire Alarm) input	•	•
Tailgating / Cross over	• / •	• / •
Number of sensor pairs (Transmitter / Receiver)	24	18 / 26*
Pushthrough* / Pressure Sensing Top*	- / •	- / •
Induction loop system for detection of bicycles and scooters	-	-
Fail-Safe motor ^[1] / MDD motor	• / -	• / -
Safety & Security mode (5 settings)	•	•
Barrier opening time (s)	0.7	0.7
Communication Interface		
Relay Inputs / Outputs	• / •	• / •
RS485 / USB* / Ethernet*	• / • / •	• / • / •
Operating Environment		
Indoor / Outdoor covered ^[2] / Outdoor uncovered	• / - / -	• / - / -
Extreme weather condition	-	-
Optional Features		
Integrated RFID reader bracket - flush mounted	•	•
Access Light / Lane Light / Edge Light	• / • / •	• / • / •
Passage Light / Wing Light / WAV Player	• / - / •	• / - / •
Identification or Ticket Terminals	-	•
Implementation of: Lift controller / Visitor Card collector / BarCode scanner	• / • / •	• / • / •
Optional Remote Control Systems		
Remote control (EasyTouch, TouchPanel)	•	•
TMON software application (remote control from any PC) / Passage Scheduler (automatic planner)	• / •	• / •
Optional Power Supply Input		
13.8 V DC / 230 V AC or 110 V AC	• / •	• / •
SuperCap	•	•
Optional Finishes		
Custom surface finish	-	•
Custom Top Lid material / Custom cladding material	- / -	- / -
Optional Mounting Accessories		
Ramp LT / Mounting console	• / •	• / •

[1] Free-to-move without power
• = Available

[2] Stainless steel tube wing
- = Not available

[3] Only with stainless steel Top Lid
* Optional accessories

[4] Only for 940 mm high glass wing
[6] Different dimensions of cabinet

[5] Only for square cabinet

[7] The roof needs to overlap the turnstile sufficiently

LC

IM

SPT-G / R & SPTs-G / R

SPD-G / R & SPDs-G / R

SG / SR 1000



- / •	- / •	• / •	• / •	• / •
• / •	• / •	• / •	• / •	• / •
990 / 38.98"	995 / 39.17"	990 / 38.98"	990 / 38.98"	990 / 38.98"
1 400 / 55.12"	1 500 / 59.10"	1 500 / 59.06" & 1 200 / 47.24"	1 500 / 59.06" & 1 200 / 47.24"	1 000 / 39.37"
150 / 5.90"	210 / 8.27"	180 / 7.09"	180 / 7.09"	120 / 4.72"
up to 1 800 / 70.87"	up to 1 800 / 70.87"	up to 1 800 / 70.87"	850 / 33.46"	835 / 32.87"
10 / 0.39"	10 / 0.39"	10 / 0.39"	10 / 0.39"	10 / 0.39"
•	•	•	•	•
• / -	- / •	• / -	• / -	• / -
- / • / -	- / - / •	- / • / -	- / • / -	- / • / -
•	•	•	•	•
• / •	• / •	• / •	• / •	• / •
36	36	36 & 24	36 & 24	24
- / •	• / -	• / • [3]	• / • [3]	- / -
-	-	-	-	-
• / -	- / •	- / •	- / •	• / -
•	•	•	•	•
0.7	0.5	0.5	0.5	0.7
• / •	• / •	• / •	• / •	• / •
• / • / •	• / • / •	• / • / •	• / • / •	• / • / •
• / - / -	• / - / -	• / - / -	• / - / -	• / - / -
-	-	-	-	-
•	•	•	•	•
• / • / -	• / • / -	• / • / •	• / • / •	• / • / -
- / • / •	- / • / •	- / • / •	- / • / •	- / • / •
•	•	•	•	•
• / • / •	• / • / •	• / • / •	• / • / •	- / - / •
•	•	•	•	•
• / •	• / •	• / •	• / •	• / •
• / •	- / •	- / •	- / •	• / •
•	•	•	•	•
-	•	•	•	•
- / -	• / •	• / • [5]	• / • [5]	• / • [5]
• / •	• / •	• / •	• / •	• / •

EasyGate – Sliding Technology & Special Applications Overview

LG



LX / LH



SPT Outdoor



Type	LG	LX / LH	SPT Outdoor
Shape of cabinet - rounded / square	• / -	• / •	• / •
Available models - 1 wing / 2 wings	- / •	- / •	• / •
Dimensions			
Cabinet Height in mm (inches)	990 / 38.98*	990 / 38.98*	990 / 38.98*
Cabinet Length in mm (inches)	1 550 / 61.02*	1 700 / 66.93*	1 500 / 59.06*
Cabinet Width in mm (inches)	330 / 12.99*	320 / 12.60*	210 / 8.30*
Glass wing barrier height in mm (inches)	up to 1 800 / 70.87*	up to 1 800 / 70.87*	up to 1 800 / 70.87*
Glass wing barrier thickness in mm (inches)	8 / 0.31*	8 / 0.31*	10 / 0.39*
DDA (ADA) Compliant	•	•	•
Standard Material			
Stainless steel cabinet (AISI 304) / Special material	• / -	• / -	• / -
Stainless steel top lid (AISI 304) / Glass top lid	• / -	• / -	- / •
Safety Features			
Emergency (Fire Alarm) input	•	•	•
Tailgating / Cross over	• / •	• / •	• / •
Number of sensor pairs (Transmitter / Receiver)	42	40	36
Pushthrough* / Pressure Sensing Top*	- / •	- / -	• / -
Induction loop system for detection of bicycles and scooters	-	-	• [6]
Fail-Safe motor [1] / MDD motor	- / •	• / -	- / •
Safety & Security mode (5 settings)	•	•	•
Barrier opening time (s)	0.4	0.5	0.5
Communication Interface			
Relay Inputs / Outputs	• / •	• / •	• / •
RS485 / USB* / Ethernet*	• / • / •	• / • / •	• / • / •
Operating Environment			
Indoor / Outdoor covered ^[7] / Outdoor uncovered	• / - / -	• / - / -	• / • / •
Extreme weather condition	-	-	-
Optional Features			
Integrated RFID reader bracket - flush mounted	•	•	•
Access Light / Lane Light / Edge Light	• / • / -	• / • / -	• / • / -
Wing Light / WAV Player	• [4] / •	• [4] / •	- / •
Identification or Ticket Terminals	•	•	-
Implementation of: Lift controller / Visitor Card collector / BarCode scanner	• / • / •	• / • / •	- / - / •
Optional Remote Control Systems			
Remote control (EasyTouch, TouchPanel)	•	•	•
TMON software application (remote control from any PC) / Passage Scheduler (automatic planner)	• / •	• / •	• / •
Optional Power Supply Input			
13.8 V DC / 230 V AC or 110 V AC	- / •	• / •	- / •
SuperCap	•	•	•
Optional Finishes			
Custom surface finish	•	•	•
Custom Top Lid material / Custom cladding material	• / -	• / • [5]	- / -
Optional Mounting Accessories			
Ramp LT / Mounting console	• / -	• / -	• / •

[1] Free-to-move without power
• = Available

[2] Stainless steel tube wing
- = Not available

[3] Only with stainless steel Top Lid
* Optional accessories

[4] Only for 940 mm high glass wing
[6] Different dimensions of cabinet

[5] Only for square cabinet

[7] The roof needs to overlap the turnstile sufficiently

SPA



SBG



e-Gate



SPT-G Bike / SPT-R Bike



SPT-G / SPT-R Bike Outdoor



Interlock Gate



- / •	- / •	- / •	• / •	• / •	• / •
- / •	- / •	- / •	• / •	• / •	- / •
1 400 / 55.12"	990 / 38.98"	990 / 38.98"	975 / 38.39"	990 / 38.98"	975 / 38.39"
1 200 / 47.24"	1 500 / 59.05"	2 870 / 112.99"	1 500 / 59.06"	1 500 / 59.06"	2 900 / 114.17"
180 / 7.09"	210 / 8.27"	240 / 9.45"	180 / 7.09"	210 / 8.30"	180 / 7.09"
1 400 / 55.12"	990 / 38.97"	up to 1 800 / 70.87"	up to 1 800 / 70.87"	up to 1 800 / 70.87"	up to 1 800 / 70.87"
10 / 0.39"	10 / 0.39"	10 / 0.39"	10 / 0.39"	10 / 0.39"	10 / 0.39"
•	•	•	•	•	•
• / -	• / -	• / -	• / -	• / -	• / -
• / -	• / -	• / -	- / •	- / •	- / •
•	•	•	•	•	•
• / •	• / •	• / •	• / •	• / •	• / •
27	36	78	36	36	75
• / -	• / -	• / -	• / • [3]	• / -	• / • [3]
-	-	-	•	• [6]	-
- / •	- / •	- / •	• / •	• / •	- / •
•	•	•	•	•	•
0.5	0.5	0.5	0.7	0.7	0.5
• / •	• / •	• / •	• / •	• / •	• / •
• / • / •	• / - / -	• / - / -	• / • / •	• / • / •	• / - / -
• / - / -	• / - / -	• / - / -	• / - / -	• / • / •	• / - / -
-	-	-	-	-	-
•	•	•	•	•	•
- / • / -	- / • / -	- / • / -	• / • / •	• / • / -	• / • / •
• / •	• / •	• / •	- / •	- / •	• / •
-	-	-	•	•	•
- / - / •	- / - / •	- / - / •	• / • / •	• / - / •	• / • / •
•	•	•	•	•	•
• / •	• / •	• / •	• / •	• / •	• / •
- / •	- / •	- / •	- / •	- / •	- / •
•	•	•	•	•	•
•	•	•	•	•	•
- / -	- / -	- / -	• / • [5]	- / -	• / • [5]
• / •	• / •	• / •	• / •	• / •	• / •

Options & Accessories



EASYTOUCH – turnstile remote control console with an intuitive graphical user interface



TOUCHPANEL – Touch-button panel for remote control of turnstiles and gates



TMON SOFTWARE – software application for easy remote control of the turnstiles and gates



RF REMOTE CONTROL – for convenient remote opening of speed gates



ACCESS LIGHT – access control light with integrated RFID bracket



LANE LIGHT – front mounted lane accessibility light panel



EDGE LIGHT – information multicolour LED light belt

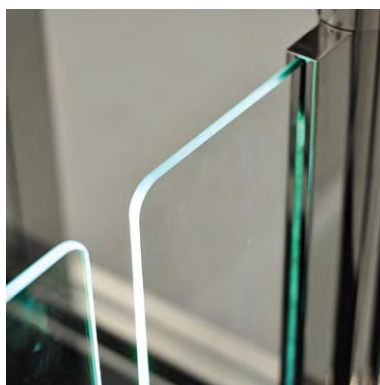

WING LIGHT – light illumination of glass wing barrier



WAV PLAYER – sound signaling device for audio confirmation of turnstile operation mode

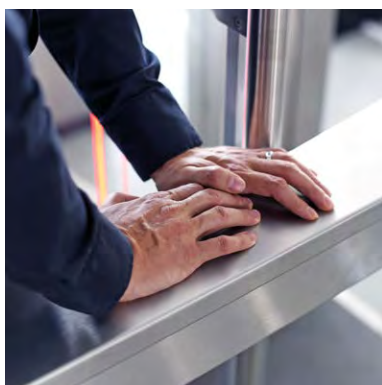

PRESSURE SENSING TOP – pressure sensing device integrated in top lid to detect climb over

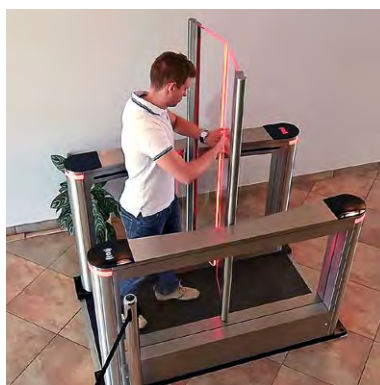

PUSHTHROUGH – allows the turnstiles to be set with the hard lock only in the entry direction

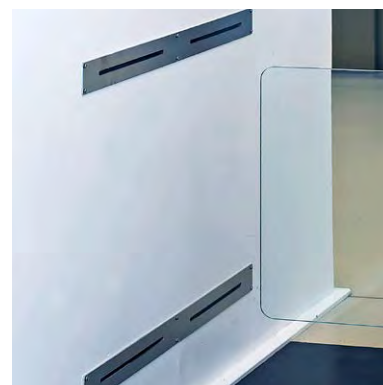

SENSOR WALL – optical sensors for EasyGate turnstile with wall mount



CARD/BADGE COLLECTOR – visitor card collector available in a stand-alone pole or Built-in versions.



EASYSKAN – RFID reader, Barcode and QR code scanner in one device, flush mouted in EasyGate cabinet.



TICKETING TERMINAL – external implementation of identification terminals

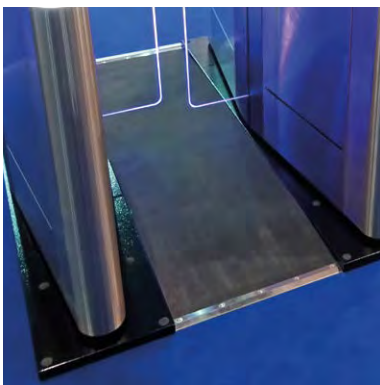

RAMP LT – for installation on floor where drilling/cutting is not allowed



MOUNTING CONSOLE – mounting console for raised/suspended floor

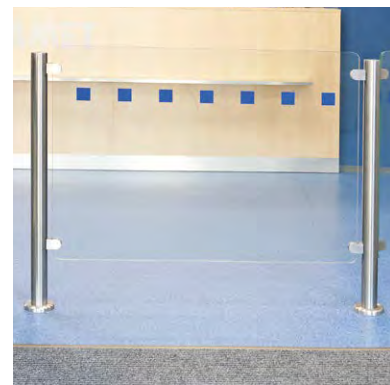

GLASS INFILL BARRIER – convenient way to aesthetically enclose the secure areas from public area



ALTERNATIVE SURFACE FINISH – polished stainless steel/brushed stainless steel/etc.



BARCODE AND QR CODE SCANNER



ALTERNATIVE TOP LID – wood, stone, corian, glass etc.



LIFT CONTROLLER – integration of lift controller



PASSAGE LIGHT – illumination of Top Lid edges, different operation modes



SUPERCAP – maintenance-free power package for Emergency opening of turnstile/gate

Project Design

Every project varies in its specifics, it can therefore be hard to choose from a standard turnstile range. We want you to realise your project visions, thus we offer you a turnstile range that can be customised to your desires.

We always seek for the perfect solutions for your projects; whether you need a higher level of security or a change of colour, surface finish or cabinet styling; whether you desire a bespoke material or to integrate other devices into the turnstile; our team will provide expert guidance to help you customise your turnstile solutions, to unlock your imagination to create the turnstile that best fits your specifications.

As part of the service we are able to provide 3D images to help you visualise how your new turnstile will look in site.



EasyGate SPD with black painted pedestal and black corian cladding



EasyGate IM with a stone cladding

EasyGate Integration

EasyGate Integration is a unique concept of integrating the EasyGate turnstile with other devices such as REA::Ticket terminal, EasyScan, RFID reader, Card/Badge collector, all developed by COMINFO and they are compatible with any 3rd party access control systems even with biometrics devices like facial recognition camera, fingerprint scanner, palm recognition, lift controller etc. All the integrations ensure direct communication between the speedgate and access control system, while maintaining the standard or customized cabinet design without external brackets, cables or other distracting elements.



EasyGate SPT with integrated MorphoWave contactless fingerprint scanner



All in one: Integration of RFID reader, barcode scanner, facial recognition camera and lift controller in EasyGate SPD cabinet while maintaining the standard dimensions



ed. 06-2024

Specifications are subject to change without prior notice.



COMINFO, a.s.

Nabrezi 695, 760 01 Zlín - Prstné, Czech Republic

T +420 603 151 333

cominfo@cominfo.cz

www.cominfo.eu

cominfo
By **GUNNEBO** Entrance Control